

52cm integrated rangehood in dark stainless steel with baffle filter, Hob2Hood and LED lighting.



Product Details

FEATURES

Dark Stainless Steel

Baffle filter

Hob2Hood

Hob2Hood automatically adjusts your hood settings so you can focus on creating delicious dishes.

700m3/hr extraction

LED lights

Electronic controls

Fully variable fan speed

Including an intensive speed

BENEFITS

ATTRACTS AS IT EXTRACTS

AEGs baffle filter design is sleek and functional. The durable stainless-steel filter efficiently extracts vapours, absorbs odours and filters grease to prevent build-ups in order to optimize the airflow. Its easy to remove and replace, and is dishwasher safe.

THE HANDS-FREE HOOD

The Hob2Hood function controls your cooker hoods fan and lights, automatically regulating the fan leaving your hands free and mind clear to focus on cooking. If youd prefer to adjust the fan speed yourself, there are manual controls on the cooker hood too; its your choice.

LET'S CLEAR THE AIR

Intense levels of extraction efficiently remove cooking odours and vapours so you can enjoy fresh kitchen air, faster.

BENEFIT FROM LONG-LASTING LIGHTING

Clear, bright LED lighting comes into its own in the kitchen, making ideal task lighting when cooking over a cooktop. And more good news, it's long-lasting and energy-efficient, too.

Specifications

PRODUCT PROFILE

Domestic warranty details (yrs)	5
---------------------------------	---

Type of Rangehood	integrated
-------------------	------------

Nominal width (cm)	60
--------------------	----

Finish of Rangehood	Dark stainless steel
---------------------	----------------------

DIMENSIONS

Total product height (mm)	329
---------------------------	-----

Total product width (mm)	520
--------------------------	-----

Total product depth (mm)	300
--------------------------	-----

Diameter of ducting (mm)	150
--------------------------	-----

Minimum installation height from cooking surface Gas (mm)	650
---	-----

MOTOR/FAN

Number of fans	2
----------------	---

Number of fans speeds	3
-----------------------	---

Auto off	Yes
----------	-----

Type of motor	centrifugal
---------------	-------------

Maximum airflow M3/Hr	680
-----------------------	-----

Noise level dB high	70
---------------------	----

Noise level dB low	53
--------------------	----

POWER

Connection plug	10
-----------------	----

DIMENSIONS

Minimum installation height from cooking surface Electric (mm)	600
Cut out width (mm)	495
Cut out depth (mm)	263
Cut out height (mm)	330

CONTROLS

Control panel	electronic push button
Safety/ display indicators	clean filter indicator,automatic safety cut off
Hob2Hood function	Yes

LIGHTS

Number of lights	2
Wattage of light	2.2
Type of light	LED

FILTERS

Number of filters	2
Type of filter	stainless steel baffle
Dishwasher safe	Yes

DUCTING / RECIRCULATION

Ducting	optional accessory
Top or rear duct hole	top
Recirculation option	Yes
Front recirculating option	No

DUCTING / RECIRCULATION

Optional extension flue	Yes
-------------------------	-----

Ducting diameter (mm)	150
-----------------------	-----

SHIPPING

Shipping Volume (m3)	0.095
----------------------	-------

Shipping Weight (Kg)	10
----------------------	----

Pack Dimensions Height (mm)	430
-----------------------------	-----

Pack Dimension Width (mm)	605
---------------------------	-----

Pack Dimension Depth (mm)	365
---------------------------	-----

Dimensions

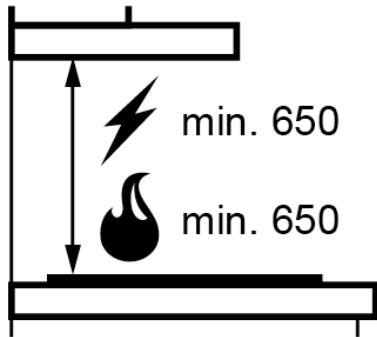
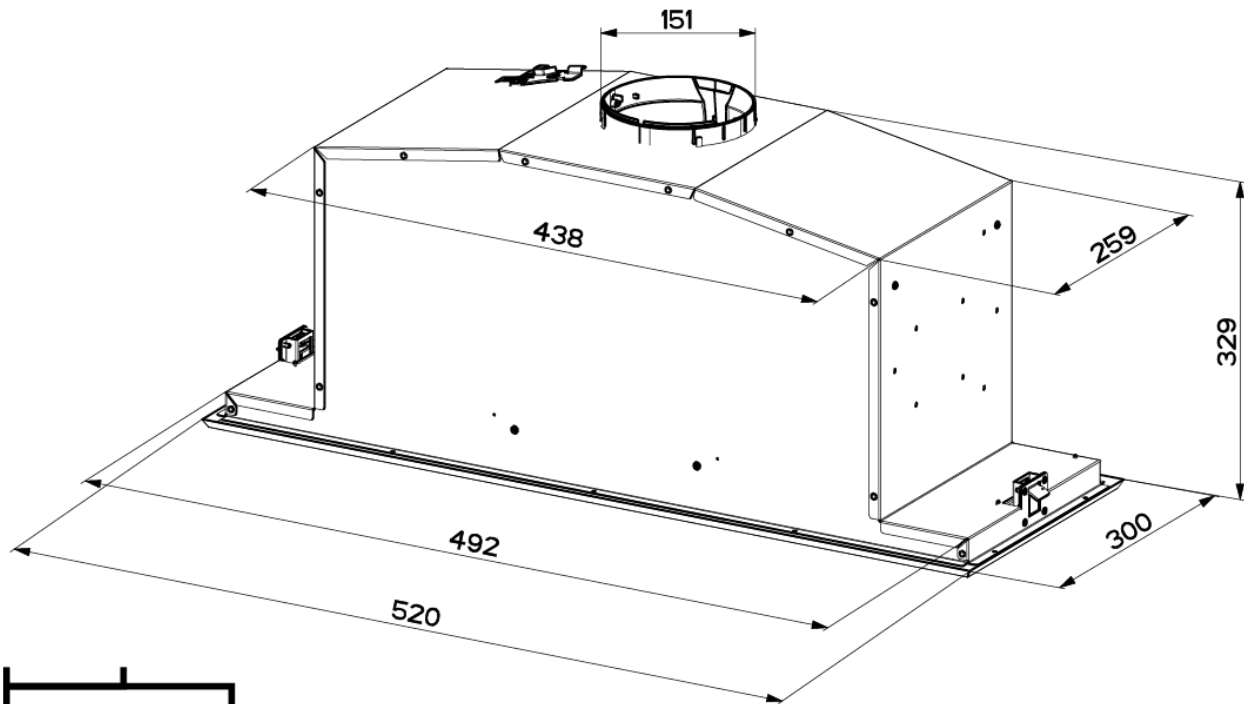

IMPORTANT

These dimensions are a guide only. All measurements are in millimetres (mm). For complete installation instructions, refer to the manual provided with product.

Terms and Conditions

IMPORTANT

This is a guide of product dimensions only. For complete installation instructions, refer to the manual provided with product.

PRODUCT INFORMATION

The descriptors and illustrations in this publication apply to the specific products and models described as at the date of issue. Under our policy of continuous product development, product specifications may change without notice. Prospective purchasers should therefore check with their retailer to ensure this publication correctly describes the products that are being offered for sale. All information supplied is to be used for general reference purposes only and is on the understanding that Electrolux Home Products Pty Ltd (Australia) and Electrolux (NZ) Ltd (New Zealand) will not be liable for any loss, liability or damage of whatever kind arising as a result of reliance on such information. Colours of products illustrated are as close as printing limitations allow. Electrolux will at all times comply with its obligations pursuant to law including Trade Practices (Australian Consumer Law) Act and Regulations.

WARRANTY

Electrolux Home Products warrants that for domestic applications the AEG appliances featured are free from defects in materials and workmanship for 5 years (3 months warranty for commercial applications). All warranties are subject to the conditions set out in the warranty card accompanying the product when purchased.

ELECTROLUX HOME PRODUCTS AUSTRALIA

telephone: 1300 363 664

fax: 1800 350 067

email: customercare@aegaustralia.com.au

web: www.aeg.com/au

ELECTROLUX HOME PRODUCTS NEW ZEALAND

telephone: 0800 10 66 10

fax: 09 573 2221

email: customercare@electrolux.co.nz

web: www.aeg.com/au