

90cm inclined canopy rangehood in matte black with SilenceTech, Hob2Hood, breeze function and dimmable LED lighting.



Product Details

FEATURES

SilenceTech

Operation noise as low as 43db(A)

Hob2Hood
Hob2Hood automatically adjusts your hood settings so you can focus on creating delicious dishes.

Breeze function

750m3/hr extraction

Intensive extraction setting

5 fan speeds

Electronic touch controls

Dimmed LED lighting

BENEFITS

ALL COOKING VAPOURS REMOVED IN SILENCE

With SilenceTech, AEGs innovative technology, the hood efficiently clears your kitchen of unwanted cooking vapours with a virtually silent operation, so you can cook in a pleasantly clean and quiet kitchen.

THE HANDS-FREE HOOD

The Hob2Hood function controls your cooker hoods fan and lights, automatically regulating the fan leaving your hands free and mind clear to focus on cooking. If you prefer to adjust the fan speed yourself, there are manual controls on the cooker hood too; its your choice.

THE NEED FOR SPEED

Three fan speeds, as well as two additional intensive extraction settings, clear cooking vapours quickly and efficiently, leaving the air in your kitchen fresh and clean.

A BREATH OF FRESH AIR

Activate Breeze Function after cooking for additional, effortless extraction of unpleasant odours that you'll barely hear, cleaning your kitchen air quietly. The extraction level is cut to a whisper-quiet minimum after you've finished cooking.

DIMMABLE LED FOR THE RIGHT LIGHT

Task lighting for cooking, mood lighting for dining: this hood with dimmable LED lights has kitchen ambience covered. Simply adjust the light intensity to adapt to your kitchen and leave the decision of bright lights when cooking or soft light when dining up to you.

Specifications

PRODUCT PROFILE

Domestic warranty details (yrs)	5
Type of Rangehood	wall mounted canopy
Nominal width (cm)	90
Finish of Rangehood	matte black

DIMENSIONS

Total product height (mm)	1260
Total product width (mm)	896

MOTOR/FAN

Number of fans	1
Number of fans speeds	5
Variable speed control	Yes
Auto off	Yes
Type of motor	centrifugal
Perimeter extraction	Yes
Maximum airflow M3/Hr	750
Noise level dB low	43
Number of motors	1
Wattage of motor	138

POWER

Electricity supply required (Kw)	144
Connection plug	10

DIMENSIONS

Total product depth (mm)	456
Diameter of ducting (mm)	150
Minimum installation height from cooking surface Gas (mm)	500
Minimum installation height from cooking surface Electric (mm)	500

CONTROLS

Control panel	touch on glass controls
Safety/ display indicators	clean filter indicator,automatic safety cut off
Hob2Hood function	Yes

LIGHTS

Number of lights	1
Wattage of light	6
Type of light	dimmer-controlled LED light

FILTERS

Number of filters	2
Type of filter	multilayer aluminum micromesh filters
Dishwasher safe	Yes

DUCTING / RECIRCULATION

Ducting	optional accessory
Top or rear duct hole	top
Recirculation option	Yes
Recirculation kit	optional accessory

DUCTING / RECIRCULATION

Type of filter	Carbon
----------------	--------

Filter	Optional
--------	----------

Ducting diameter (mm)	150
-----------------------	-----

SHIPPING

Shipping Volume (m3)	0.388
----------------------	-------

Shipping Weight (Kg)	31.3
----------------------	------

Pack Dimensions Height (mm)	600
-----------------------------	-----

Pack Dimension Width (mm)	1010
---------------------------	------

Pack Dimension Depth (mm)	640
---------------------------	-----

Dimensions

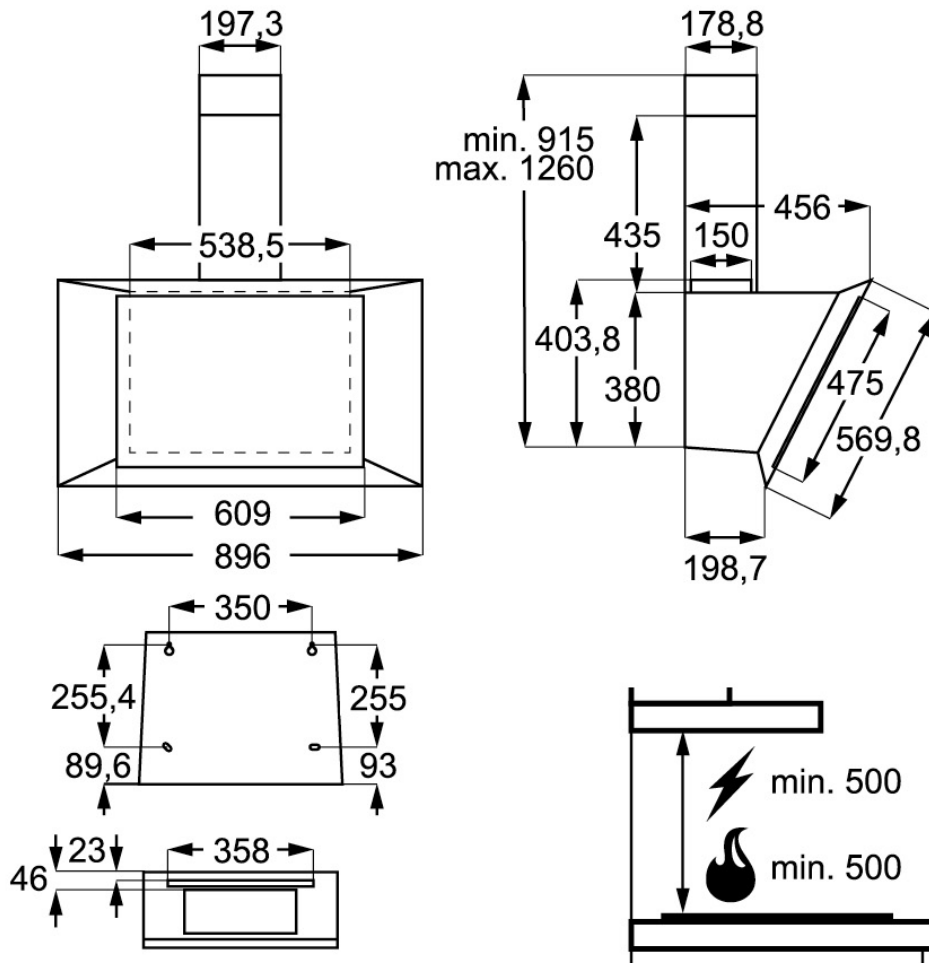

IMPORTANT

These dimensions are a guide only. All measurements are in millimetres (mm).
For complete installation instructions, refer to the manual provided with product.

Terms and Conditions

IMPORTANT

This is a guide of product dimensions only. For complete installation instructions, refer to the manual provided with product.

PRODUCT INFORMATION

The descriptors and illustrations in this publication apply to the specific products and models described as at the date of issue. Under our policy of continuous product development, product specifications may change without notice. Prospective purchasers should therefore check with their retailer to ensure this publication correctly describes the products that are being offered for sale. All information supplied is to be used for general reference purposes only and is on the understanding that Electrolux Home Products Pty Ltd (Australia) and Electrolux (NZ) Ltd (New Zealand) will not be liable for any loss, liability or damage of whatever kind arising as a result of reliance on such information. Colours of products illustrated are as close as printing limitations allow. Electrolux will at all times comply with its obligations pursuant to law including Trade Practices (Australian Consumer Law) Act and Regulations.

WARRANTY

Electrolux Home Products warrants that for domestic applications the AEG appliances featured are free from defects in materials and workmanship for 5 years (3 months warranty for commercial applications). All warranties are subject to the conditions set out in the warranty card accompanying the product when purchased.

ELECTROLUX HOME PRODUCTS AUSTRALIA

telephone: 1300 363 664

fax: 1800 350 067

email: customercare@aegaustralia.com.au

web: www.aeg.com/au

ELECTROLUX HOME PRODUCTS NEW ZEALAND

telephone: 0800 10 66 10

fax: 09 573 2221

email: customercare@electrolux.co.nz

web: www.aeg.com/au